

Operating Instructions

RI FB PRO/i
RI MOD/i CC Ethernet/IP-2P



DE | Bedienungsanleitung

EN-US | Operating instructions



Inhaltsverzeichnis

Allgemeines	4
Sicherheit	4
Anschlüsse und Anzeigen	4
Eigenschaften der Datenübertragung	5
Konfigurationsparameter	5
IP-Adresse des Busmoduls einstellen	7
IP-Adresse des Busmoduls einstellen	7
Ein- und Ausgangssignale	9
Datentypen	9
Verfügbarkeit der Eingangssignale	9
Eingangssignale (vom Roboter zur Stromquelle)	9
Wertebereich Working mode	14
Wertebereich Documentation mode	14
Wertebereich Process controlled correction	15
Wertebereich Processline selection	15
Wertebereich TWIN mode	15
Verfügbarkeit der Ausgangssignale	16
Ausgangssignale (von der Stromquelle zum Roboter)	16
Zuordnung Sensorstatus 1-4	19
Wertebereich Safety status	19
Wertebereich Process Bit	20

Allgemeines

Sicherheit

WARNUNG!

Gefahr durch Fehlbedienung und fehlerhaft durchgeführte Arbeiten.

Schwere Personen- und Sachschäden können die Folge sein.

- ▶ Alle in diesem Dokument beschriebenen Arbeiten und Funktionen dürfen nur von technisch geschultem Fachpersonal ausgeführt werden.
- ▶ Dieses Dokument vollständig lesen und verstehen.
- ▶ Sämtliche Sicherheitsvorschriften und Benutzerdokumentationen dieses Gerätes und aller Systemkomponenten lesen und verstehen.

Anschlüsse und Anzeigen

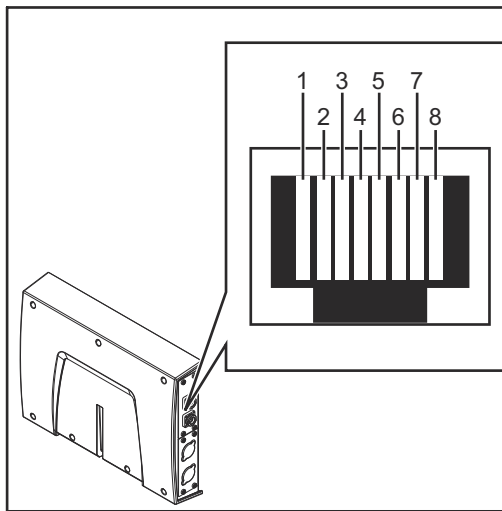

Pin-Belegung RJ 45 ProfiNet Anschluss

1	TX+
2	TX-
3	RX+
6	RX-
4,5,7,8	Normalerweise nicht verwendet; um die Signalfullständigkeit sicherzustellen, sind diese Pins miteinander verbunden und enden über einen Filterkreis am Schutzleiter (PE).

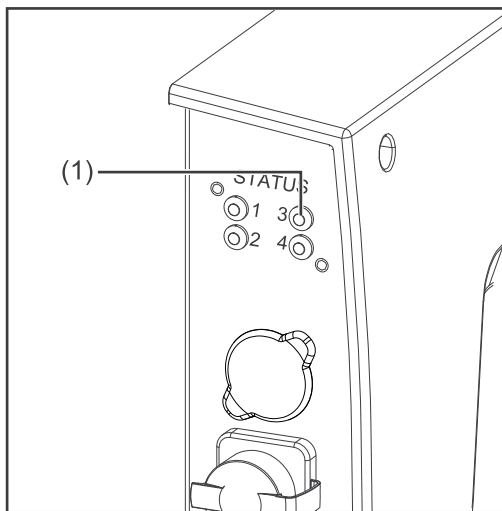

(1) LED MS - Modulstatus

Aus:

keine Versorgungsspannung

Leuchtet grün:

gesteuert durch einen Master

Blinkt grün (einmal):

Master nicht konfiguriert oder im Ruhezustand

Leuchtet rot:

Hauptfehler (Ausnahmezustand, schwerer Fehler, ...)

Blinkt rot:

behebbarer Fehler

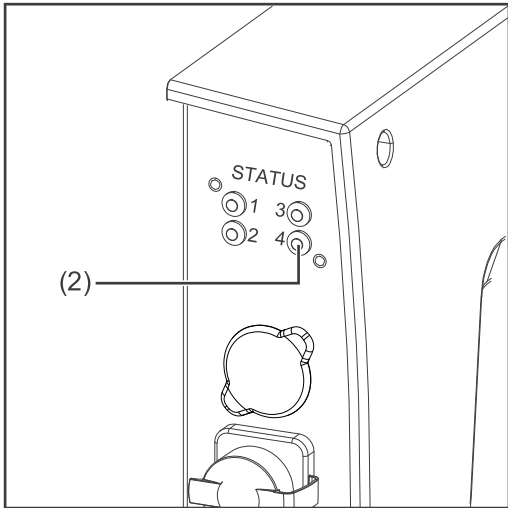

(2) LED NS - Netzwerkstatus	
Aus:	keine Versorgungsspannung oder keine IP-Adresse
Leuchtet grün:	Online; eine oder mehrere Verbindungen hergestellt (CIP Kategorie 1 oder 3)
Blinkt grün:	Online; keine Verbindung hergestellt
Leuchtet rot:	doppelte IP-Adresse, schwerer Fehler
Blinkt rot:	Zeitüberlauf bei einer oder mehreren Verbindungen (CIP Kategorie 1 oder 3)

Eigenschaften der Datenübertragung

Übertragungstechnik
Ethernet

Medium

Bei der Auswahl der Kabel und Stecker ist die ODVA Empfehlung für die Planung und Installation von EtherNet/IP Systemen zu beachten.

Seitens Hersteller wurden die EMV-Tests mit dem Kabel IE-C5ES8VG0030-M40M40-F durchgeführt.

Übertragungs-Geschwindigkeit

10 Mbit/s or 100 Mbit/s

Busanschluss

RJ-45 Ethernet / M12

Konfigurationsparameter

Bei einigen Robotersteuerungen kann es erforderlich sein die hier beschriebenen Konfigurationsparameter anzugeben, damit das Busmodul mit dem Roboter kommunizieren kann.

Parameter	Wert	Beschreibung
Vendor ID	0534 _{hex} (1332 _{dez})	Fronius International GmbH
Device Type	000C _{hex} (12 _{dez})	Communication adapter
Product Code	0320 _{hex} (800 _{dez})	Fronius FB Pro Ethernet/IP-2-Port
Product Name	Fronius-FB-Pro-EtherNetIP(TM)	

Image Type	Instance Type	Instance Name	Instance Description	Instance Number	Size [Byte]
Standard Image	Producing Instance	Input Data Standard	Data from power source to robot	100	40
	Consuming Instance	Output Data Standard	Data from robot to power source	150	40
Economy Image	Producing Instance	Input Data Standard	Data from power source to robot	101	16
	Consuming Instance	Output Data Standard	Data from robot to power source	151	16

IP-Adresse des Busmoduls einstellen

IP-Adresse des Busmoduls einstellen

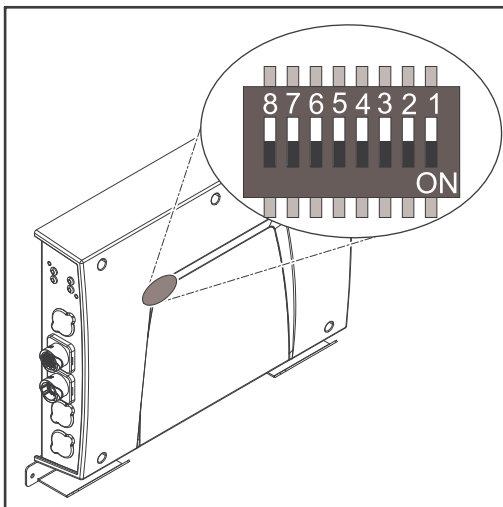

Die IP-Adresse des Busmoduls kann eingestellt werden:

1. mit dem DIP-Schalter im Interface im Bereich 192.168.0.xx (xx = DIP-Schalterstellung = 1 bis 63)
 - Werkseitig sind alle Positionen in Stellung OFF geschaltet. In diesem Fall muss die IP-Adresse auf der Website der Stromquelle eingestellt werden
2. auf der Website der Stromquelle (wenn alle Positionen des DIP-Schalters in Stellung OFF geschaltet sind)

Die IP-Adresse wird mit den Positionen 1 bis 6 des DIP-Schalters eingestellt. Die Einstellung erfolgt im Binärformat. Das ergibt einen Einstellbereich von 1 bis 63 im Dezimalformat.

Beispiel für das Einstellen der IP-Adresse des Busmoduls mit dem DIP-Schalter im Interface:

DIP-Schalter								IP-Adresse
8	7	6	5	4	3	2	1	
-	-	OFF	OFF	OFF	OFF	OFF	ON	1
-	-	OFF	OFF	OFF	OFF	ON	OFF	2
-	-	OFF	OFF	OFF	OFF	ON	ON	3
-	-	ON	ON	ON	ON	ON	OFF	62
-	-	ON	ON	ON	ON	ON	ON	63

Anleitung für das Einstellen der IP-Adresse auf der Website der Stromquelle:

IP-Adresse der verwendeten Stromquelle notieren:

- 1 Am Bedienpanel der Stromquelle „Voreinstellungen“ auswählen
- 2 Am Bedienpanel der Stromquelle „System“ auswählen
- 3 Am Bedienpanel der Stromquelle „Information“ auswählen
- 4 Angezeigte IP-Adresse notieren (Beispiel: 10.5.72.13)

Website der Stromquelle im Internetbrowser aufrufen:

- 5 Computer mit dem Netzwerk der Stromquelle verbinden
- 6 IP-Adresse der Stromquelle in die Suchleiste des Internetbrowsers eingeben und bestätigen
- 7 Standard-Benutzernamen (admin) und Passwort (admin) eingeben
 - Website der Stromquelle wird angezeigt

IP-Adresse des Busmoduls einstellen:

- 8 Auf der Website der Stromquelle den Reiter „RI FB PRO/i“ auswählen

- 9 Bei Punkt „Feldbus Konfiguration“ die gewünschte IP-Adresse für das Interface eingeben
Beispielsweise: 192.168.0.12
- 10 „Konfiguration setzen“ auswählen
- 11 „Feldbus-Modul neu starten“ auswählen
 - die eingestellte IP-Adresse wird übernommen

Ein- und Ausgangssignale

Datentypen

Folgende Datentypen werden verwendet:

- **UINT16** (Unsigned Integer)
Ganzzahl im Bereich von 0 bis 65535
- **SINT16** (Signed Integer)
Ganzzahl im Bereich von -32768 bis 32767

Umrechnungsbeispiele:

- für positiven Wert (SINT16)
z.B. gewünschter Drahtvorschub x Faktor
 $12.3 \text{ m/min} \times 100 = 1230_{\text{dez}} = 04\text{CE}_{\text{hex}}$
- für negativen Wert (SINT16)
z.B. gewünschte Lichtbogen-Korrektur x Faktor
 $-6.4 \times 10 = -64_{\text{dez}} = \text{FFCO}_{\text{hex}}$

Verfügbarkeit der Eingangssignale

Die nachfolgend angeführten Eingangssignale sind ab Firmware V1.7.0 des RI FB PRO/i verfügbar.

Eingangssignale (vom Roboter zur Stromquelle)

Adresse				Signal	Aktivität / Datentyp	Bereich	Faktor	Prozess-Image	
relativ		absolut						Standard	Economy
WORD	BYTE	BIT	BIT						
0	0	0	0	Welding Start	steigend			✓	✓
		1	1	Robot ready	High				
		2	2	Working mode Bit 0	High	Siehe Tabelle Wertebereich Working mode auf Seite 14			
		3	3	Working mode Bit 1	High				
		4	4	Working mode Bit 2	High				
		5	5	Working mode Bit 3	High				
		6	6	Working mode Bit 4	High				
	7	7	—						
	1	0	8	Gas on	steigend				
		1	9	Wire forward	steigend				
		2	10	Wire backward	steigend				
		3	11	Error quit	steigend				
		4	12	Touch sensing	High				
		5	13	Torch blow out	steigend				
		6	14	Processline selection Bit 0	High	Siehe Tabelle Wertebereich Processline selection auf Seite 15			
7	15	Processline selection Bit 1	High						
1	2	0	16	Welding Simulation	High				
		1	17	Synchro pulse on	High				
		2	18	—					
		3	19	—					
		4	20	—					
		5	21	—					
		6	22	Wire brake on	High				
	7	23	Torchbody Xchange	High					
	3	0	24	—					
		1	25	Teach mode	High				
		2	26	—					
		3	27	—					
		4	28	—					
		5	29	Wire sense start	steigend				
6		30	Wire sense break	steigend					
7	31	—							

Adresse				Signal	Aktivität / Datentyp	Bereich	Faktor	Prozess-Image	
relativ		absolut						Standard	Economy
WORD	BYTE	BIT	BIT						
2	4	0	32	TWIN mode Bit 0	High	Siehe Tabelle Wertebereich TWIN mode auf Seite 15	✓	✓	
		1	33	TWIN mode Bit 1	High				
		2	34	—					
		3	35	—					
		4	36	—					
		5	37	Documentation mode	High	Siehe Tabelle Wertebereich Documentation mode auf Seite 14			
		6	38	—					
		7	39	—					
	5	0	40	—					
		1	41	—					
		2	42	—					
		3	43	—					
		4	44	—					
		5	45	—					
6		46	—						
	7	47	Disable process controlled correction	High					

Adresse				Signal	Aktivität / Datentyp	Bereich	Faktor	Prozess-Image		
relativ		absolut						Standard	Economy	
WORD	BYTE	BIT	BIT							
3	6	0	48	—				✓	✓	
		1	49	—						
		2	50	—						
		3	51	—						
		4	52	—						
		5	53	—						
		6	54	—						
	7	55	—							
	7	0	56	ExtInput1 => OPT_Output 1	High					
		1	57	ExtInput2 => OPT_Output 2	High					
		2	58	ExtInput3 => OPT_Output 3	High					
		3	59	ExtInput4 => OPT_Output 4	High					
		4	60	ExtInput5 => OPT_Output 5	High					
		5	61	ExtInput6 => OPT_Output 6	High					
6		62	ExtInput7 => OPT_Output 7	High						
7	63	ExtInput8 => OPT_Output 8	High							
4	8	0-7	64-71	Welding characteristic- / Job number	UINT16	0 bis 1000	1	✓	✓	
	9	0-7	72-79							
5	10, 11	0-7	80-95	<i>Beim Schweißverfahren MIG/MAG Puls-Synergic, MIG/MAG Standard-Synergic, MIG/MAG Standard-Manuell, MIG/MAG PMC, MIG/MAG LSC, CMT, ConstantWire:</i> Wire feed speed command value	SINT16	-327,68 bis 327,67 [m/min]	100	✓	✓	
				<i>Beim Job-Betrieb:</i> Power correction	SINT16	-20,00 bis 20,00 [%]	100			

Adresse				Signal	Aktivität / Datentyp	Bereich	Faktor	Prozess-Image	
relativ		absolut	Standard					Economy	
WORD	BYTE	BIT							
6	12, 13	0-7	96-111	<i>Beim Schweißverfahren MIG/MAG Puls-Synergic, MIG/MAG Standard-Synergic, MIG/MAG PMC, MIG/MAG LSC, CMT:</i> Arclength correction	SINT16	-10,0 bis 10,0 [Schritte]	10	✓	✓
				<i>Beim Schweißverfahren MIG/MAG Standard-Manuell:</i> Welding voltage	UINT16	0,0 bis 6553,5 [V]	10		
				<i>Beim Job-Betrieb:</i> Arclength correction	SINT16	-10,0 bis 10,0 [Schritte]	10		
				<i>Beim Schweißverfahren ConstantWire:</i> Hotwire current	UINT16	0,0 bis 6553,5 [A]	10		
7	14, 15	0-7	112-127	<i>Beim Schweißverfahren MIG/MAG Puls-Synergic, MIG/MAG Standard-Synergic, MIG/MAG PMC, MIG/MAG LSC, CMT:</i> Pulse-/dynamic correction	SINT16	-10,0 bis 10,0 [Schritte]	10	✓	✓
				<i>Beim Schweißverfahren MIG/MAG Standard-Manuell:</i> Dynamic	UINT16	0,0 bis 10,0 [Schritte]	10		
8	16	0-7	128-135	Wire retract correction	UINT16	0,0 bis 10,0 [Schritte]	10	✓	
	17	0-7	136-143						
9	18	0-7	144-151	Welding speed	UINT16	0,0 bis 1000,0 [cm/min]	10	✓	
	19	0-7	152-159						
10	20	0-7	160-167	Process controlled correction		Siehe Tabelle Wertebereich Process controlled correction auf Seite 15		✓	
	21	0-7	168-175						

Adresse				Signal	Aktivität / Datentyp	Bereich	Faktor	Prozess-Image	
relativ		absolut	Standard					Economy	
WORD	BYTE	BIT							
11	22	0-7	176-183	—				✓	
	23	0-7	184-191						
12	24	0-7	192-199	—				✓	
	25	0-7	200-207						
13	26	0-7	208-215	—				✓	
	27	0-7	216-223						
14	28	0-7	224-231	—				✓	
	29	0-7	232-239						
15	30	0-7	240-247	Wire forward / backward length	UINT16	OFF / 1 bis 65535 [mm]	1	✓	
	31	0-7	248-255						
16	32	0-7	256-263	Wire sense edge detection	UINT16	OFF / 0,5 bis 20,0 [mm]	10	✓	
	33	0-7	264-271						
17	34	0-7	272-279	—				✓	
	35	0-7	280-287						
18	36	0-7	288-295	—				✓	
	37	0-7	296-303						
19	38	0-7	304-311	Seam number	UINT16	0 bis 65535	1	✓	
	39	0-7	312-319						

Wertebereich Working mode

Bit 4	Bit 3	Bit 2	Bit 1	Bit 0	Beschreibung
0	0	0	0	0	Parameterwahl intern
0	0	0	0	1	Kennlinien Betrieb Sonder 2-Takt
0	0	0	1	0	Job-Betrieb
0	1	0	0	0	Kennlinien Betrieb 2-Takt
0	1	0	0	1	MIG/MAG Standard-Manuell 2-Takt
1	0	0	0	1	Kühlmittel-Pumpe stoppen

Wertebereich Betriebsart

Wertebereich Documentation mode

Bit 0	Beschreibung
0	Nahtnummer von Stromquelle (intern)
1	Nahtnummer von Roboter (Word 19)

Wertebereich Dokumentationsmodus

**Wertebereich
Process controlled
correction**

Prozess	Signal	Aktivität / Datentyp	Wertebereich Einstellbereich	Einheit	Faktor
PMC	Arc length stabilizer	SINT16	-327,8 bis +327,7 0,0 bis +5,0	Volt	10

Wertebereich prozessabhängige Korrektur

**Wertebereich
Processline
selection**

Bit 1	Bit 0	Beschreibung
0	0	Prozesslinie 1 (default)
0	1	Prozesslinie 2
1	0	Prozesslinie 3
1	1	Reserviert

Wertebereich Prozesslinien-Auswahl

**Wertebereich
TWIN mode**

Bit 1	Bit 0	Beschreibung
0	0	TWIN Single mode
0	1	TWIN Lead mode
1	0	TWIN Trail mode
1	1	Reserve

Wertebereich TWIN-Betriebsart

**Verfügbarkeit
der Ausgangssi-
gnale**

Die nachfolgend angeführten Ausgangssignale sind ab Firmware V1.7.0 des RI FB PRO/i verfügbar.

**Ausgangssignale
(von der Strom-
quelle zum Ro-
boter)**

Adresse				Signal	Aktivität / Datentyp	Bereich	Faktor	Prozess- Image	
relativ		absolut						Standard	Economy
WORD	BYTE	BIT	BIT						
0	0	0	0	Heartbeat Powersource	High/Low	1 Hz			
		1	1	Power source ready	High				
		2	2	Warning	High				
		3	3	Process active	High				
		4	4	Current flow	High				
		5	5	Arc stable- / touch signal	High				
		6	6	Main current signal	High				
		7	7	Touch signal	High				
	1	0	8	Collisionbox active	Low	0 = Kollisi- on oder Kabel- bruch	✓	✓	
		1	9	Robot Motion Release	High				
		2	10	Wire stick workpiece	High				
		3	11	—					
		4	12	Short circuit contact tip	High				
		5	13	Parameter selection in- ternally	High				
		6	14	Characteristic number valid	High				
7	15	Torch body gripped	High						

Adresse				Signal	Aktivität / Datentyp	Bereich	Faktor	Prozess-Image		
relativ		absolut						Standard	Economy	
WORD	BYTE	BIT	BIT							
1	2	0	16	Command value out of range	High			✓	✓	
		1	17	Correction out of range	High					
		2	18	—						
		3	19	Limitsignal	High					
		4	20	—						
		5	21	—						
		6	22	Main supply status	Low					
	7	23	—							
	3	0	24	Sensor status 1	High	Siehe Tabelle Zuordnung Sensorstatus 1-4 auf Seite 19				
		1	25	Sensor status 2	High					
		2	26	Sensor status 3	High					
		3	27	Sensor status 4	High					
		4	28	—						
		5	29	—						
6		30	—							
2	4	0	32	—						
		1	33	—						
		2	34	—						
		3	35	Safety status Bit 0	High	Siehe Tabelle Wertebereich Safety status auf Seite 19				
		4	36	Safety status Bit 1	High					
		5	37	—						
		6	38	Notification	High					
	7	39	System not ready	High						
	5	0	40	—						
		1	41	—						
		2	42	—						
		3	43	—						
		4	44	—						
		5	45	—						
6		46	—							
7	47	—								

Adresse				Signal	Aktivität / Datentyp	Bereich	Faktor	Prozess-Image	
relativ		absolut						Standard	Economy
WORD	BYTE	BIT	BIT						
3	6	0	48	Process Bit 0	High	Siehe Tabelle Wertebereich Process Bit auf Seite 20			
		1	49	Process Bit 1	High				
		2	50	Process Bit 2	High				
		3	51	Process Bit 3	High				
		4	52	Process Bit 4	High				
		5	53	—					
		6	54	Touch signal gas nozzle	High				
	7	55	TWIN synchronization active	High					
	7	0	56	ExtOutput1 <= OPT_Input1	High			✓	✓
		1	57	ExtOutput2 <= OPT_Input2	High				
		2	58	ExtOutput3 <= OPT_Input3	High				
		3	59	ExtOutput4 <= OPT_Input4	High				
		4	60	ExtOutput5 <= OPT_Input5	High				
		5	61	ExtOutput6 <= OPT_Input6	High				
6		62	ExtOutput7 <= OPT_Input7	High					
7	63	ExtOutput8 <= OPT_Input8	High						
4	8	0-7	64-71	Welding voltage	UINT16	0,0 bis 655,35 [V]	100	✓	✓
	9	0-7	72-79						
5	10	0-7	80-87	Welding current	UINT16	0,0 bis 6553,5 [A]	10	✓	✓
	11	0-7	88-95						
6	12	0-7	96-103	Wire feed speed	SINT16	-327,68 bis 327,67 [m/min]	100	✓	✓
	13	0-7	104-111						
7	14	0-7	112-119	Actual real value for seam tracking	UINT16	0 bis 6,5535	10000	✓	✓
	15	0-7	120-127						
8	16	0-7	128-135	Error number	UINT16	0 bis 65535	1	✓	
	17	0-7	136-143						
9	18	0-7	144-151	Warning number	UINT16	0 bis 65535	1	✓	
	19	0-7	152-159						

Adresse				Signal	Aktivität / Datentyp	Bereich	Faktor	Prozess-Image				
relativ		absolut	WORD					BYTE	BIT	BIT	Standard	Economy
10	20	0-7	160-167	Motor current M1	SINT16	-327,68 bis 327,67 [A]	100	✓				
	21	0-7	168-175									
11	22	0-7	176-183	Motor current M2	SINT16	-327,68 bis 327,67 [A]	100	✓				
	23	0-7	184-191									
12	24	0-7	192-199	Motor current M3	SINT16	-327,68 bis 327,67 [A]	100	✓				
	25	0-7	200-207									
13	26	0-7	208-215	—				✓				
	27	0-7	216-223									
14	28	0-7	224-231	—				✓				
	29	0-7	232-239									
15	30	0-7	240-247	—				✓				
	31	0-7	248-255									
16	32	0-7	256-263	Wire position	SINT16	-327,68 bis 327,67 [mm]	100	✓				
	33	0-7	264-271									
17	34	0-7	272-279	—				✓				
	35	0-7	280-287									
18	36	0-7	288-295	—				✓				
	37	0-7	296-303									
19	38	0-7	304-311	—				✓				
	39	0-7	312-319									

Zuordnung Sensorstatus 1-4

Signal	Beschreibung
Sensor status 1	OPT/i WF R Drahtende (4,100,869)
Sensor status 2	OPT/i WF R Drahtfass (4,100,879)
Sensor status 3	OPT/i WF R Ringsensor (4,100,878)
Sensor status 4	Drahtpufferset CMT TPS/i (4,001,763)

Wertebereich Safety status

Bit 1	Bit 0	Beschreibung
0	0	Reserve
0	1	Halt
1	0	Stopp

Bit 1	Bit 0	Beschreibung
1	1	Nicht eingebaut / aktiv

**Wertebereich
Process Bit**

Bit 4	Bit 3	Bit 2	Bit 1	Bit 0	Beschreibung
0	0	0	0	0	kein Prozess oder Parameterwahl intern
0	0	0	0	1	MIG/MAG Puls-Synergic
0	0	0	1	0	MIG/MAG Standard-Synergic
0	0	0	1	1	MIG/MAG PMC
0	0	1	0	0	MIG/MAG LSC
0	0	1	0	1	MIG/MAG Standard-Manuell
0	0	1	1	0	Elektrode
0	0	1	1	1	WIG
0	1	0	0	0	CMT
0	1	0	0	1	ConstantWire

Table of contents

General.....	22
Safety.....	22
Connections and Displays.....	22
Data Transfer Properties.....	23
Configuration Parameters.....	23
Setting the Bus Module IP Address.....	25
Setting the Bus Module IP Address.....	25
Input and output signals.....	27
Data types.....	27
Availability of Input Signals.....	27
Input Signals (From Robot to Power Source).....	27
Value Range for Working Mode.....	33
Value Range for Documentation Mode.....	33
Value range for Process controlled correction.....	34
Value range Process line selection.....	34
Value Range for TWIN Mode.....	34
Availability of Output Signals.....	35
Output Signals (from Power Source to Robot).....	35
Assignment of Sensor Statuses 1–4.....	38
Value range Safety status.....	38
Value Range for Process Bit.....	39

General

Safety

WARNING!

Danger from incorrect operation and work that is not carried out properly.

This can result in serious personal injury and damage to property.

- ▶ All the work and functions described in this document must only be carried out by technically trained and qualified personnel.
- ▶ Read and understand this document in full.
- ▶ Read and understand all safety rules and user documentation for this equipment and all system components.

Connections and Displays

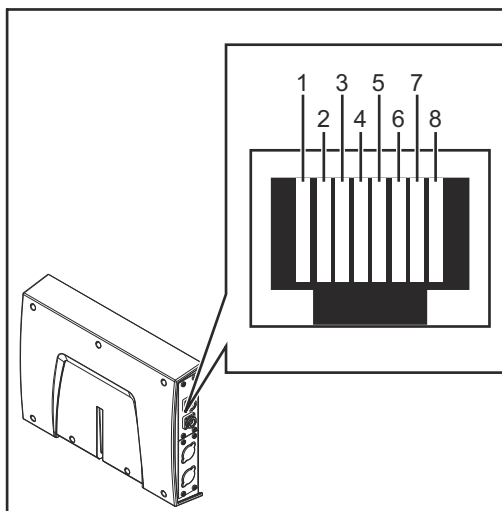

RJ45 connection

1	TX+
2	TX-
3	RX+
6	RX-
4,5,7,8	Not normally used; to ensure signal completeness, these pins must be interconnected and, after passing through a filter circuit, must terminate at the ground conductor (PE).

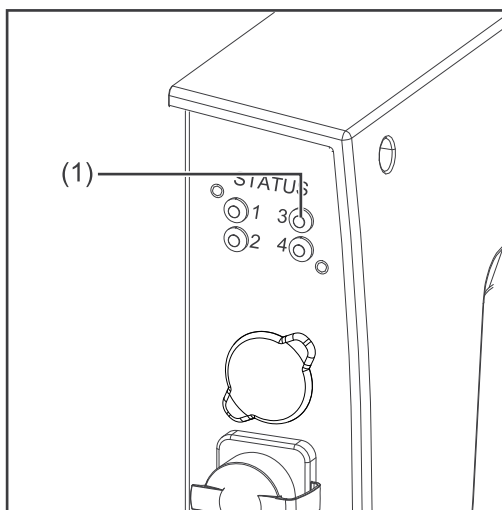

(1) LED MS - Module status

Off:

No supply voltage

Lights up green:

Controlled by a master

Flashes green (once):

Master not configured or master idle

Lights up red:

Major error (exception state, serious fault, ...)

Flashes red:

Correctable error

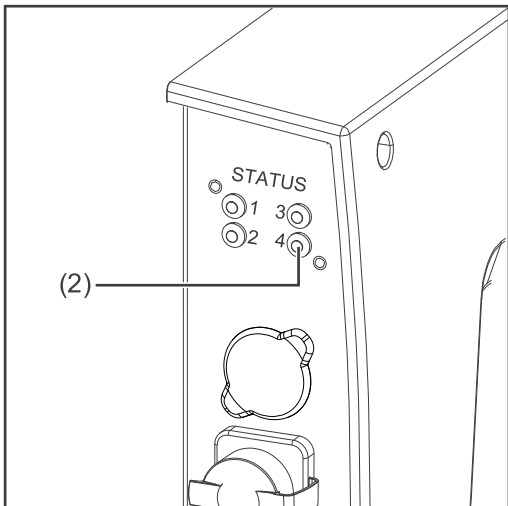

(2) LED NS - Network status	
Off:	No supply voltage or no IP address
Lights up green:	Online, one or more connections established (CIP category 1 or 3)
Flashes green:	Online, no connection established
Lights up red:	Double IP address, serious error
Flashes red:	Overrun of time for one or more connections (CIP category 1 or 3)

Data Transfer Properties

Transfer technology	Ethernet
Medium	When selecting the cables and plugs, the ODVA recommendation for the planning and installation of EtherNet/IP systems must be observed. The EMC tests were carried out by the manufacturer with the cable IE-C5ES8VGO030M40M40-F.
Transmission speed	10 Mbit/s or 100 Mbit/s
Bus connection	RJ-45 Ethernet / M12

Configuration Parameters

In some robot control systems, it may be necessary to state the configuration parameters described here so that the bus module can communicate with the robot.

Parameter	Value	Description
Vendor ID	0534 _{hex} (1332 _{dec})	Fronius International GmbH
Device Type	000C _{hex} (12 _{dec})	Communication adapter
Product Code	0320 _{hex} (800 _{dec})	Fronius FB Pro Ethernet/IP-2-Port
Product Name	Fronius-FB-Pro-EtherNetIP(TM)	

Image Type	Instance Type	Instance Name	Instance Description	Instance Number	Size [Byte]
Standard Image	Producing Instance	Input Data Standard	Data from power source to robot	100	40

Image Type	Instance Type	Instance Name	Instance Description	Instance Number	Size [Byte]
	Consuming Instance	Output Data Standard	Data from robot to power source	150	40
Economy Image	Producing Instance	Input Data Standard	Data from power source to robot	101	16
	Consuming Instance	Output Data Standard	Data from robot to power source	151	16

Setting the Bus Module IP Address

Setting the Bus Module IP Address

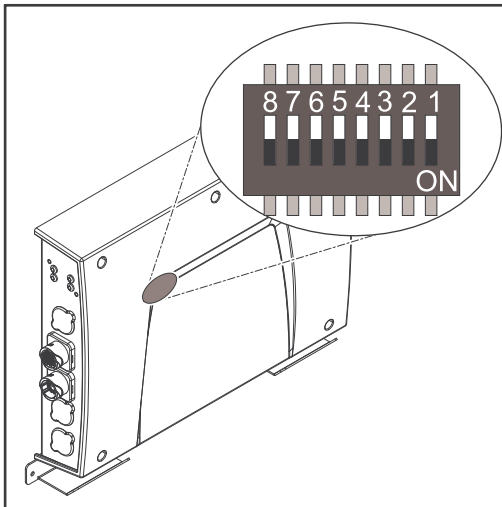

You can set the bus module IP address as follows:

1. Using the DIP switch in the interface within the range defined by 192.168.0.xx (xx = DIP switch setting = 1 to 63)
 - All positions are set to the OFF position at the factory. In this case, the IP address must be set on the website of the power source
2. On the website of the power source (if all positions of the DIP switch are set to the OFF position)

The IP address is set using DIP switch positions 1 to 6. The configuration is carried out in binary format. This results in a configuration range of 1 to 63 in decimal format.

Example for setting the IP address of the bus module using the DIP switch in the interface:								
Dip switch								
8	7	6	5	4	3	2	1	IP address
-	-	OFF	OFF	OFF	OFF	OFF	ON	1
-	-	OFF	OFF	OFF	OFF	ON	OFF	2
-	-	OFF	OFF	OFF	OFF	ON	ON	3
-	-	ON	ON	ON	ON	ON	OFF	62
-	-	ON	ON	ON	ON	ON	ON	63

Instructions for setting the IP address on the website of the power source:

Note down the IP address of the power source used:

- 1 On the power source control panel, select "Defaults"
- 2 On the power source control panel, select "System"
- 3 On the power source control panel, select "Information"
- 4 Note down the displayed IP address (example: 10.5.72.13)

Access website of the power source in the internet browser:

- 5 Connect the computer to the network of the power source
- 6 Enter the IP address of the power source in the search bar of the internet browser and confirm
- 7 Enter the standard user name (admin) and password (admin)
 - The website of the power source is displayed

Set the bus module IP address:

- 8 On the power source website, select the "RI FB PRO/i" tab

- 9** Enter the desired IP address for the interface under "Module configuration".
For example: 192.168.0.12
- 10** Select "Set configuration"
- 11** Select "Restart module"
 - The set IP address is applied

Input and output signals

Data types

The following data types are used:

- **UINT16** (Unsigned Integer)
Whole number in the range from 0 to 65535
- **SINT16** (Signed Integer)
Whole number in the range from -32768 to 32767

Conversion examples:

- for a positive value (SINT16)
e.g. desired wire speed x factor
 $12.3 \text{ m/min} \times 100 = 1230_{\text{dec}} = 04\text{CE}_{\text{hex}}$
- for a negative value (SINT16)
e.g. arc correction x factor
 $-6.4 \times 10 = -64_{\text{dec}} = \text{FFCO}_{\text{hex}}$

Availability of Input Signals

The input signals listed below are available as of firmware V1.7.0 of the RI FB PRO/i.

Input Signals (From Robot to Power Source)

Address				Signal	Activity / data type	Range	Factor	Process image	
relative		absolute						Standard	Economy
WORD	BYTE	BIT	BIT						
0	0	0	0	Welding Start	Increasing			✓	✓
		1	1	Robot ready	High				
		2	2	Working mode Bit 0	High	See table Value Range for Working Mode on page 33			
		3	3	Working mode Bit 1	High				
		4	4	Working mode Bit 2	High				
		5	5	Working mode Bit 3	High				
		6	6	Working mode Bit 4	High				
	7	7	—						
	1	0	8	Gas on	Increasing				
		1	9	Wire forward	Increasing				
		2	10	Wire backward	Increasing				
		3	11	Error quit	Increasing				
		4	12	Touch sensing	High				
		5	13	Torch blow out	Increasing				
		6	14	Process line selection Bit 0	High	See table Value range Process line selection on page 34			
7		15	Process line selection Bit 1	High					

Address				Signal	Activity / data type	Range	Factor	Process image	
relative		absolute						Standard	Economy
WORD	BYTE	BIT	BIT						
1	2	0	16	Welding Simulation	High			✓	✓
		1	17	Synchro pulse on	High				
		2	18	—					
		3	19	—					
		4	20	—					
		5	21	—					
		6	22	Wire brake on	High				
	7	23	Torchbody Xchange	High					
	3	0	24	—					
		1	25	Teach mode	High				
		2	26	—					
		3	27	—					
		4	28	—					
		5	29	Wire sense start	Increasing				
6		30	Wire sense break	Increasing					
	7	31	—						

Address				Signal	Activity / data type	Range	Factor	Process image		
relative		absolute						Standard	Economy	
WORD	BYTE	BIT	BIT							
2	4	0	32	TWIN mode Bit 0	High	See table Value Range for TWIN Mode on page 34				
		1	33	TWIN mode Bit 1	High					
		2	34	—						
		3	35	—						
		4	36	—						
		5	37	Documentation mode	High	See table Value Range for Documentation Mode on page 33			✓	✓
		6	38	—						
		7	39	—						
	5	0	40	—						
		1	41	—						
		2	42	—						
		3	43	—						
		4	44	—						
		5	45	—						
6		46	—							
7	47	Disable process controlled correction	High							

Address				Signal	Activity / data type	Range	Factor	Process image	
relative		absolute						Standard	Economy
WORD	BYTE	BIT	BIT						
3	6	0	48	—				✓	✓
		1	49	—					
		2	50	—					
		3	51	—					
		4	52	—					
		5	53	—					
		6	54	—					
	7	55	—						
	7	0	56	ExtInput1 => OPT_Output 1	High				
		1	57	ExtInput2 => OPT_Output 2	High				
		2	58	ExtInput3 => OPT_Output 3	High				
		3	59	ExtInput4 => OPT_Output 4	High				
		4	60	ExtInput5 => OPT_Output 5	High				
		5	61	ExtInput6 => OPT_Output 6	High				
6		62	ExtInput7 => OPT_Output 7	High					
7	63	ExtInput8 => OPT_Output 8	High						
4	8	0-7	64-71	Welding characteristic- / Job number	UINT16	0 to 1000	1		
	9	0-7	72-79						
5	10, 11	0-7	80-95	With the welding process MIG/MAG pulse synergic, MIG/MAG standard synergic, MIG/MAG standard manual, MIG/MAG PMC, MIG/MAG LSC, CMT, ConstantWire: Wire feed speed command value	SINT16	-327.68 to 327.67 [m/min]	100		
				With the Job mode: Power correction	SINT16	-20.00 to 20.00 [%]	100		

Address				Signal	Activity / data type	Range	Factor	Process image	
relative		absolute	Standard					Economy	
WORD	BYTE	BIT							
6	12, 13	0-7	96-111	With the welding process MIG/MAG pulse synergic, MIG/MAG standard synergic, MIG/MAG PMC, MIG/MAG LSC, CMT: Arclength correction	SINT16	-10.0 to 10.0 [Steps]	10		
				With the welding process MIG/MAG standard manual: Welding voltage	UINT16	0.0 to 6553.5 [V]	10	✓	✓
				With the Job mode: Arclength correction	SINT16	-10.0 to 10.0 [Steps]	10		
				With the welding process ConstantWire: Hotwire current	UINT16	0.0 to 6553.5 [A]	10		
7	14, 15	0-7	112-127	With the welding process MIG/MAG pulse synergic, MIG/MAG standard synergic, MIG/MAG PMC, MIG/MAG LSC, CMT: Pulse-/dynamic correction	SINT16	-10.0 to 10.0 [Steps]	10	✓	✓
				With the welding process MIG/MAG standard manual: Dynamic	UINT16	0.0 to 10.0 [Steps]	10		
8	16	0-7	128-135	Wire retract correction	UINT16	0.0 to 10.0 [Steps]	10	✓	
	17	0-7	136-143						
9	18	0-7	144-151	Welding speed	UINT16	0.0 to 1000.0 [cm/min]	10	✓	
	19	0-7	152-159						
10	20	0-7	160-167	Process controlled correction		See table Value range for Process controlled correction on page 34		✓	
	21	0-7	168-175						
11	22	0-7	176-183	—				✓	
	23	0-7	184-191						

Address				Signal	Activity / data type	Range	Factor	Process image	
relative		absolute	Standard					Economy	
WORD	BYTE	BIT							
12	24	0-7	192-199	—				✓	
	25	0-7	200-207						
13	26	0-7	208-215	—				✓	
	27	0-7	216-223						
14	28	0-7	224-231	—				✓	
	29	0-7	232-239						
15	30	0-7	240-247	Wire forward / backward length	UINT16	OFF / 1 to 65535 [mm]	1	✓	
	31	0-7	248-255						
16	32	0-7	256-263	Wire sense edge detection	UINT16	OFF / 0.5 to 20.0 [mm]	10	✓	
	33	0-7	264-271						
17	34	0-7	272-279	—				✓	
	35	0-7	280-287						
18	36	0-7	288-295	—				✓	
	37	0-7	296-303						
19	38	0-7	304-311	Seam number	UINT16	0 to 65535	1	✓	
	39	0-7	312-319						

Value Range for Working Mode

Bit 4	Bit 3	Bit 2	Bit 1	Bit 0	Description
0	0	0	0	0	Internal parameter selection
0	0	0	0	1	Special 2-step mode characteristics
0	0	0	1	0	Job mode
0	1	0	0	0	2-step mode characteristics
0	1	0	0	1	2-step MIG/MAG standard manual
1	0	0	0	1	Stop coolant pump

Value range for operating mode

Value Range for Documentation Mode

Bit 0	Description
0	Seam number of power source (internal)
1	Seam number of robot (Word 19)

Value range for documentation mode

Value range for Process controlled correction

Process	Signal	Activity / data type	Value range configuration range	Unit	Factor
PMC	Arc length stabilizer	SINT16	-327.8 to +327.7 0.0 to +5.0	Volts	10

Value range for process-dependent correction

Value range Process line selection

Bit 1	Bit 0	Description
0	0	Process line 1 (default)
0	1	Process line 2
1	0	Process line 3
1	1	Reserved

Value range for process line selection

Value Range for TWIN Mode

Bit 1	Bit 0	Description
0	0	TWIN Single mode
0	1	TWIN Lead mode
1	0	TWIN Trail mode
1	1	Reserved

Value range for TWIN mode

Availability of Output Signals

The output signals listed below are available as of firmware V1.7.0 of the RI FB PRO/i.

**Output Signals
(from Power Source to Robot)**

Address				Signal	Activity / data type	Range	Factor	Process image	
relative		absolute						Standard	Economy
WORD	BYTE	BIT	BIT						
0	0	0	0	Heartbeat Powersource	High/Low	1 Hz			
		1	1	Power source ready	High				
		2	2	Warning	High				
		3	3	Process active	High				
		4	4	Current flow	High				
		5	5	Arc stable- / touch signal	High				
		6	6	Main current signal	High				
		7	7	Touch signal	High				
	1	0	8	Collisionbox active	Low	0 = collision or cable break		✓	✓
		1	9	Robot Motion Release	High				
		2	10	Wire stick workpiece	High				
		3	11	—					
		4	12	Short circuit contact tip	High				
		5	13	Parameter selection internally	High				
		6	14	Characteristic number valid	High				
	7	15	Torch body gripped	High					

Address				Signal	Activity / data type	Range	Factor	Process image		
relative		absolute						Standard	Economy	
WORD	BYTE	BIT	BIT							
1	2	0	16	Command value out of range	High			✓	✓	
		1	17	Correction out of range	High					
		2	18	—						
		3	19	Limitsignal	High					
		4	20	—						
		5	21	—						
		6	22	Main supply status	Low					
	7	23	—							
	3	0	24	Sensor status 1	High	See table Assignment of Sensor Statuses 1–4 on page 38				
		1	25	Sensor status 2	High					
		2	26	Sensor status 3	High					
		3	27	Sensor status 4	High					
		4	28	—						
		5	29	—						
6		30	—							
7	31	—								
2	4	0	32	—				✓	✓	
		1	33	—						
		2	34	—						
		3	35	Safety status Bit 0	High	See table Value range Safety status on page 38				
		4	36	Safety status Bit 1	High					
		5	37	—						
		6	38	Notification	High					
	7	39	System not ready	High						
	5	0	40	—						
		1	41	—						
		2	42	—						
		3	43	—						
		4	44	—						
		5	45	—						
6		46	—							
7	47	—								

Address				Signal	Activity / data type	Range	Factor	Process image	
relative		absolute						Standard	Economy
WORD	BYTE	BIT	BIT						
3	6	0	48	Process Bit 0	High	See table Value Range for Process Bit on page 39			
		1	49	Process Bit 1	High				
		2	50	Process Bit 2	High				
		3	51	Process Bit 3	High				
		4	52	Process Bit 4	High				
		5	53	—					
		6	54	Touch signal gas nozzle	High				
	7	55	TWIN synchronization active	High					
	7	0	56	ExtOutput1 <= OPT_Input1	High			✓	✓
		1	57	ExtOutput2 <= OPT_Input2	High				
		2	58	ExtOutput3 <= OPT_Input3	High				
		3	59	ExtOutput4 <= OPT_Input4	High				
		4	60	ExtOutput5 <= OPT_Input5	High				
		5	61	ExtOutput6 <= OPT_Input6	High				
6		62	ExtOutput7 <= OPT_Input7	High					
7	63	ExtOutput8 <= OPT_Input8	High						
4	8	0-7	64-71	Welding voltage	UINT16	0.0 to 655.35 [V]	100	✓	✓
	9	0-7	72-79						
5	10	0-7	80-87	Welding current	UINT16	0.0 to 6553.5 [A]	10	✓	✓
	11	0-7	88-95						
6	12	0-7	96-103	Wire feed speed	SINT16	-327.68 to 327.67 [m/min]	100	✓	✓
	13	0-7	104-111						
7	14	0-7	112-119	Actual real value for seam tracking	UINT16	0 to 6.5535	10000	✓	✓
	15	0-7	120-127						
8	16	0-7	128-135	Error number	UINT16	0 to 65535	1	✓	
	17	0-7	136-143						
9	18	0-7	144-151	Warning number	UINT16	0 to 65535	1	✓	
	19	0-7	152-159						

Address				Signal	Activity / data type	Range	Factor	Process image	
relative		absolute	Standard					Economy	
WORD	BYTE	BIT							
10	20	0-7	160-167	Motor current M1	SINT16	-327.68 to 327.67 [A]	100	✓	
	21	0-7	168-175						
11	22	0-7	176-183	Motor current M2	SINT16	-327.68 to 327.67 [A]	100	✓	
	23	0-7	184-191						
12	24	0-7	192-199	Motor current M3	SINT16	-327.68 to 327.67 [A]	100	✓	
	25	0-7	200-207						
13	26	0-7	208-215	—				✓	
	27	0-7	216-223						
14	28	0-7	224-231	—				✓	
	29	0-7	232-239						
15	30	0-7	240-247	—				✓	
	31	0-7	248-255						
16	32	0-7	256-263	Wire position	SINT16	-327.68 to 327.67 [mm]	100	✓	
	33	0-7	264-271						
17	34	0-7	272-279	—				✓	
	35	0-7	280-287						
18	36	0-7	288-295	—				✓	
	37	0-7	296-303						
19	38	0-7	304-311	—				✓	
	39	0-7	312-319						

Assignment of Sensor Statuses 1–4

Signal	Description
Sensor status 1	OPT/i WF R wire end (4,100,869)
Sensor status 2	OPT/i WF R wire drum (4,100,879)
Sensor status 3	OPT/i WF R ring sensor (4,100,878)
Sensor status 4	Wire buffer set CMT TPS/i (4,001,763)

Value range Safety status

Bit 1	Bit 0	Description
0	0	Reserve
0	1	Hold
1	0	Stop
1	1	Not installed / active

Value Range for Process Bit

Bit 4	Bit 3	Bit 2	Bit 1	Bit 0	Description
0	0	0	0	0	No internal parameter selection or process
0	0	0	0	1	MIG/MAG pulse synergic
0	0	0	1	0	MIG/MAG standard synergic
0	0	0	1	1	MIG/MAG PMC
0	0	1	0	0	MIG/MAG LSC
0	0	1	0	1	MIG/MAG standard manual
0	0	1	1	0	Electrode
0	0	1	1	1	TIG
0	1	0	0	0	CMT
0	1	0	0	1	ConstantWire



Fronius International GmbH

Froniusstraße 1
4643 Pettenbach
Austria
contact@fronius.com
www.fronius.com

At www.fronius.com/contact you will find the contact details
of all Fronius subsidiaries and Sales & Service Partners.